

OPTIMAL CONTROL OF TELECOMMUNICATION AEROPLATFORM IN THE AREA OF EMERGENCY

Oleksandr I. Lysenko¹, Stanislav V. Valuiskyi^{1,2}, Pavel I. Kirchu², Anton V. Romaniuk¹

¹National technical university of Ukraine “KPI”, Kyiv, Ukraine

²Research Center of problems of aviation and aviation search and rescue, Kyiv, Ukraine

This paper addresses to a method for increasing of mobile ad-hoc networks throughput based on the placement control of unmanned aerial vehicles in the area of emergency situation. A further development of this method, namely the improvement of UAV flight control subsystem, that will allow operative implementation of obtained in the previous stage location coordinates while minimizing energy consumption for control, is proposed. The proposed approach will improve network throughput by 15–20% while reducing fuel costs by an average of 13–15%.

Introduction

The main criteria of the effectiveness of civil protection system in the aftermath of emergency situations of natural or anthropogenic origin are efficiency and cost, i.e. to minimize the time and resources for search and rescue, detection and localization of potentially dangerous objects, etc. This is possible through the deployment of mobile ad hoc networks (MANET) using telecommunications aeroplatfrom (Fig. 1) [1]. Subscribers of such networks (rescuers, sensors or vehicles) can communicate with each other (or coordination center) on the basis of temporary connections with relay messages through intermediate ground or airborne nodes. Not only aviation facilities of Ministry of Emergency Situations (An–32P, Mi–8 and EC–145), but the unmanned aircraft systems of mini- and micro- class can be used as air repeaters.

Development of such UAV is conducted actively in many countries, including Ukraine. In particular, the National Technical University of Ukraine “KPI” developed a miniature UAV prototype (Fig. 2). Building MANET using such aeroplatfrom will greatly enhance the efficiency of rescuer units functioning in carrying out of search and rescue operations and reduce costs for their organization on the order.

However, the functioning of such MANET is not possible without an effective control system, which would allow respond quickly to structural and functional changes, providing certain control objectives, including improving network throughput, subscribers connectivity, reliability, survivability, and others.

Many well-known domestic and foreign scientists worked in this area [2–4]. In particular, prof. Romaniuk V.A. proposed the functional model of UAVs network control system [5], the main components of which are

the topology control subsystem and flight control subsystem. The topology control subsystem determines the optimal UAVs placement according to selected criteria and directs flight control subsystem to perform the specified goals, such as improving network throughput.

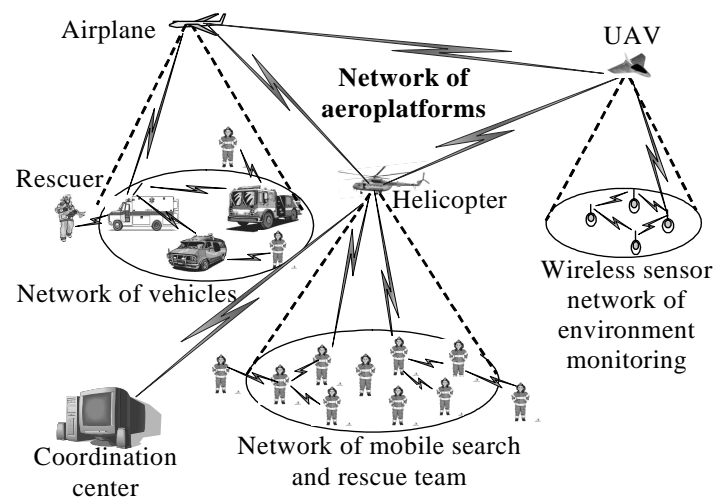

Fig.1. Example of MANET organization using aerial repeaters



Fig.2. Miniature UAV prototype (developed in National Technical University of Ukraine “KPI”)

In [6–8] was proposed UAV network topology control method, which is a computational procedure, that allows operatively determine the close to the optimal location of UAVs set on the criterion of maximum network throughput. However, in practice, not only efficient computation aeroplatform location, but also the operational implementation of solutions by the flight control system in limiting fuel costs in terms of intensive stochastic external disturbances in the area of emergency situation is necessary. In this aspect this method will get further development in this work.

Thus the *purpose* of this paper is synthesis of optimal by energy consumption flight control system of telecommunication aeroplatform in the area of emergency situation.

General description of the method

First, we formulate a general statement of the problem. Assume that the following initial data is: current position coordinates and velocity of mobile subscribers (MS) $X_i = [x_i, y_i, z_i], \vec{v}_i, i = \overline{1, N}$, where N is number of MS in the network; the current position coordinates and velocity of the UAVs $X_{0k} = [x_{0k}, y_{0k}, z_{0k}], \vec{V}_{0k}, k = \overline{1, K}$, where K is number of UAVs in the network; maximum range of transmission (reception) of MS d^0 and UAVs D^0 (in the plane of UAVs) and R^0 (in the plane of MSs), which are the same for all nodes; minimum duration of MS connectivity T_{con}^0 ; parameters of radio channels: V – transfer rate, L – data packet length, which are the same for all nodes; requirements for traffic – the minimum capacity s^0 and maximum transmission delay t_D^0 , multiple access (MAC) protocols – Carrier Sense Multiple Access With Collision Avoidance (CSMA/CA) for MS-MS and MS-UAV channels and Frequency Division Multiple Access (FDMA) for UAV-UAV channels; algorithm for finding the shortest path – Dijkstra; all subscribers are without priority to be maintained, that is traffic distribution matrix G – homogeneous; traffic type – homogeneous Poisson without priority of service; type of packets service in network nodes – with the expectation of unlimited length queue; MS movement model – random walk in a field, which is considered in detail in [9].

Network throughput S is a function of the location of nodes X (MS and UAV), because the location of nodes determines network structure, namely the potential data routes between MS. Optimal selection of the location of some nodes (in this case UAV) will create a network

topology that has a large number of independent routes, and thus to improve its throughput.

Then the *general formulation of the problem* can be formulated as follows: to find the UAVs placement (network connectivity matrix C_k) to maximize network throughput S , ie

$$S = f(X) \rightarrow \max_{X \in \Omega}, \quad (1)$$

where Ω – admitted region, defined by requirements for connectivity (Ω_1) and operation (Ω_2) of MANET; $X = [X_{01}, \dots, X_{0k}]$, where $X_{01} = [x_{01}, y_{01}, z_{01}], \dots, X_{0k} = [x_{0k}, y_{0k}, z_{0k}], k = \overline{1, K}$. Detailed mathematical formulation of the problem is given in [8].

To solve problem (1) a method was developed. This method is based on the idea of increasing MANET throughput using UAVs placement control.

The *main point of idea* is that to find the optimal placement of UAVs in space, which allows creating such a network structure, which has larger number of independent data-transfer routes between subscribers. According to the Ford-Falkerson theorem it allows to increase the minimum cross-section and the maximum flow that the network can pass in unit of time, i.e. to increase its throughput.

To implement the proposed idea, the following techniques were developed and combined into a single computational procedure: methodology of estimation of connectivity of network structure [9], methodology of estimation of performance parameters in the routes of network [10], an improved algorithm for finding the optimal placement of UAVs [8]. These techniques are shown in Fig. 3 by rectangles with dashed lines 1,2,3 respectively.

Detailed scheme-algorithm of proposed method is shown in Fig. 3. It includes the following steps: gathering information about the condition and the network operation parameters (block 1); prediction of MS connectivity duration, based on models rescuers movement during the execution of search and rescue operations (blocks 2,3), calculation and estimation of parameters of network structure connectivity (blocks 4,5), calculation and estimation of parameters of network operation (blocks 7, 8); finding a new UAV location in case of deviation of structural or functional network parameters from the permissible values, which implements the given aim of control (maximum of network throughput) (blocks 6,9,10); implementation of the solution (launch or moving of UAV to a given position in space) (block 11) and adaptation to the real conditions of operation (block 12). This cycle implemented consistently and efficiently for each UAV depending on how much has changed network topology with respect to its previous

state (determined by the nature and level of mobility subscribers [9]).

The algorithm for finding a new position of UAV in general reduces to the search of all the possible variants of UAV's placement. However, this problem belongs to the class of NP-complete, so to reduce the exhaustive search of variants of UAV's placement the use of the pre-designed *set of rules* for selection of variants of such changes of network connectivity is proposed, that increases its throughput and reduces the computation time. This enables to get close to optimal real-time solutions and use an algorithm for operative control of UAVs position. The detailed scheme of this algorithm (in case of increase of network throughput) is considered in detail in [8].

average throughput gain of the proposed method over existing ones (using during cellular network planing) is 15–20%, and 2) the average deviation of performance relative to exhaustive search method is 5–7%, and 3) the average time of receiving the decision of the proposed method is a one/tenth seconds as opposed to tens of minutes for the existing methods to perform management position aircraft (UAV) in real time.

However, determining the optimal position in real time does not guarantee its immediate implementation, so that the subject of further development of method is to solve the problem of synthesis of optimal flight control law to perform the obtained decision in the shortest possible time. That is we will carry out the detailed block 11 of the scheme in Figure 3.

Improved UAV flight control system

A specific property of small size UAV as object of control (OC) is the fact that it operates in unstable weather conditions, heavy traffic of air vehicles and intense stochastic external disturbances. This leads to the fact that the spatial position of aeroplatform is changing uncertainly in a wide range, which leads to the instability of radio coverage area and negatively effects on quality of functioning of telecommunications networks.

Despite significant advances in the theory of operational synthesis of optimal control laws [11,12], for small size UAV the problem of the development of simple and fast algorithms for operational synthesis of control laws remains unresolved, which maintain the stability and quality of control system under uncertain OC parameters changes, presence of intensive stochastic external disturbances, limited available energy of UAV, and which allow to support quality of functioning of telecommunications network in the specified limits. Therefore, extremely important is the task of developing a method of synthesis of adaptive optimal energy consumption control law of aircraft type small size UAV, which is used as a telecommunication aeroplatform for MANET.

Let the object of control (UAV) is described by the equation of state:

$$\begin{aligned} \dot{X} &= A(t)X(t) + B(t)U(t) + \eta(t); \\ Y &= CX(t) + \xi(t), \end{aligned} \tag{2}$$

where $X \in R^n$ is vector of OC state; $U \in R^n$ is vector of control; Y is vector of measurements; $A(t)$, $B(t)$ are $n \times n$ and $n \times m$ matrices of OC parameters; η and ξ is vectors of noise disturbance and noise measurement.

The vector of state variables has the form $X = [u, w, q, \theta, H, \Omega]^T$, where u is velocity relative to the axis x , w is velocity relative to the the axis z , q is

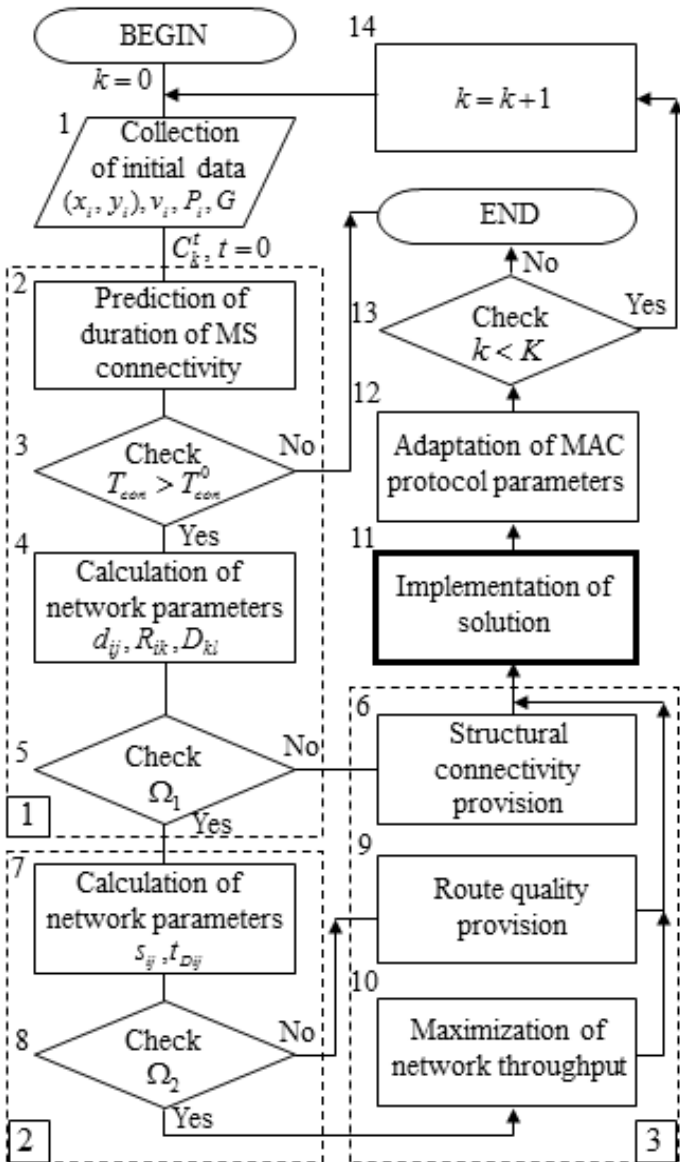

Fig.3. Scheme-algorithm of method for increasing throughput of MANET using UAVs

An evaluation of the effectiveness of the proposed method leads to the following conclusions: 1) the

angular velocity of the pitch, θ is pitch angle, H is height, Ω is frequency of rotation of the output shaft of the motor.

For side-channel vector of state variables has the form $X = [v, p, r, \varphi, \psi]^T$, where v is velocity relative to the axis y , p is roll angular velocity, r is yaw angular velocity, φ is angle of heel, ψ is the angle of yaw.

Vector of control has the form $U = [\delta_E, \delta_H]^T$, where δ_E is angular deviation of ailerons, δ_H is rudder deviation of direction, and the output vector, where β is the angle of sliding.

The opportunity of dimension or restoration of the whole OC state vector is assumed, so $X_B = X(t)$. Using the algorithm presented in [13], we consider the problem of provision by OC the desired dynamics while minimizing energy consumption for control. Desired dynamics of OC while minimizing energy consumption for control will be set by the reference model

$$\dot{X}_M = A_M X_M(t) + B_M R(t), \quad (3)$$

where $X_M \in R^n$ is state vector of the reference model, $R \in R^m$ is vector of input actions.

Let's formalize the purpose of control, requiring that

$$\lim_{t \rightarrow \infty} E(t) = 0 \quad (4)$$

where $E(t) = X(t) - X_M(t)$ is error of system (2) and (3). Thus, the problem concerns the synthesis of adaptive system with explicit reference model is posed. Let the OC is affected by measurable disturbance (specified actions) $R=R(t)$, disturbances which are not measured $N=N(t)$ and the control action $U=U(t)$. Output variables of object $X_B=X(t)$ are available for observations. Behavior of OC depends on several independent parameters which denote ζ . Given a set Ξ of possible values ζ , which determines the allowable class object and disturbances. Given a purpose of control (4), which defines the desired behavior of OC. It is necessary to synthesize control algorithm, which uses the measured or calculated based on the measured values, which are independent of $\zeta \in \Xi$, and providing for every $\zeta \in \Xi$ achievement of the control goals. Vector ζ consists of the coefficients of the equations that constitute the mathematical description (2) of OC, as well as the coefficients that determine changes in external disturbances (environmental conditions). Furthermore, vector ζ includes abstraction parameters that describe perturbations that are not measured, which are caused by inaccurate description of OC. Vector ζ deemed to be slowly changing.

Then the statement of the problem can be formulated as follows: find a control algorithm

$$U(t) = U_t(X(t), U(t), \Theta(t), R(t)), \quad (5)$$

$$\Theta(t) = \Theta_t(X(t), U(t), \Theta(t), R(t)), \quad (6)$$

which achieves goals of control (4) in the system (2), (3), (5), (6) for each $\zeta \in \Xi$. Here $\Theta(t)$ is vector of parameters of the regulator. During the finding of control algorithms (5), (6), it is necessary to consider the restrictions on the parameters of UAV motion, namely restrictions on the maximum and minimum angles of roll and pitch, as well as restrictions on the height of flight.

A generalized procedure for the method of synthesis of adaptive control algorithm with a reference model consists of the following steps: 1) formulation of the problem of synthesis, 2) synthesis of optimal reference model, 3) synthesis of optimal state observer (Kalman filter), 4) selection of the structure of the regulator (the synthesis of the main circuit), 5) selection of adjustable parameters, 6) the choice of algorithm adaptation, 7) posterization, 8) configure the adapter.

The problem of synthesis of the main circuit is solved subject to the assumption that OC parameters are known. Let us write the equation in deviations for getting the structure of "ideal" controller

$$\dot{E}(t) = A_M E(t) + (A - A_M)X(t) + BU(t) - B_M R(t). \quad (7)$$

Put requirement to the condition of equation solution

$$(A - A_M)X(t) + BU(t) - B_M R(t) = 0, \quad (8)$$

respect to $U_* \in R^m$ at any $X \in R^n$, $R \in R^m$. Ideal control that satisfies (8), described by the equation

$$U_*(t) = K_*^X X(t) + K_*^R R(t), \text{ or} \\ U_*(t) = \bar{K}_*^R \bar{K}_*^X X(t) + \bar{K}_*^R R(t), \quad (9)$$

where $K_*^X, K_*^R, \bar{K}_*^X, \bar{K}_*^R$ are matrices of ideal coefficients of the regulator, which satisfy the equation:

$$BK_*^X = A_M - A, \quad BK_*^R = B_M, \quad (10a)$$

$$B_M \bar{K}_*^X = A_M - A, \quad B \bar{K}_*^R = B_M. \quad (10b)$$

The structure of the main circuit is selected as

$$U_*(t) = \bar{K}^R(t) \bar{K}^X(t) X(t) + \bar{K}^R(t) R(t), \quad (11)$$

where $\bar{K}^X(t), \bar{K}^R(t)$ are matrices coefficients of the regulator, which are subject to setting.

For the configuration algorithms of matrices $\bar{K}^X(t)$ and $\bar{K}^R(t)$ write the equation of configuration object as

$$\dot{E}(t) = A_M E(t) + B_M \Theta(t) \Sigma(t), \quad (12)$$

where $\Theta(t) = (\Phi(t); \Psi(t))$ is expanded matrix of configurable coefficients deviations from their "ideal" values

$$\Phi(t) = \bar{K}^X(t) - \bar{K}_*^X, \quad \Psi(t) = (\bar{K}_*^R)^{-1} - [\bar{K}_*^R(t)]^{-1}, \quad (13)$$

$$\Sigma(t) = \begin{pmatrix} X(t) \\ \bar{K}^R(t)[Y(t) + \bar{K}^X(t)X(t)] \end{pmatrix}. \quad (14)$$

As Lyapunov function we take a quadratic scalar function in view

$$V = 0.5E^T HE + 0.5tr(\Theta^T \Gamma^{-1} \Theta), H = H^T, \Gamma = \Gamma^T \quad (15)$$

where H is matrix of Lyapunov, Γ is matrix of weights.

Adaptation algorithm is chosen as

$$\dot{\Theta} = -\Gamma B_M^T H E \Sigma^T(t), \quad \Gamma = \Gamma^T > 0. \quad (16)$$

As a result, the algorithm configuration matrices $\bar{K}^X(t)$ and $\bar{K}^R(t)$ can be written as

$$\begin{aligned} \dot{\bar{K}}^X(t) &= -\Gamma_1 B_M^T H E(t) X^T(t), \\ \dot{\bar{K}}^R(t) &= -\bar{K}^R \Gamma_2 B_M^T H E(t) [R + \bar{K}^X X(t)]^T \times \\ &\times (\bar{K}^R)^T \bar{K}^R. \end{aligned} \quad (17)$$

Block diagram of the adaptive system considering the structure of the generalized object configuration is shown in Fig. 4. In this algorithm external perturbation w_1 and noises of measurement sensors w_2 can be regarded as accidental changes of OC parameters, which should be tracked by adaptation circuit and adjusted matrices of regulator parameters $\bar{K}^X(t)$, $\bar{K}^Y(t)$ to achieve control objectives $E(t) \rightarrow 0$. To provide performance of optimal adaptive control system of UAV under intense action of external stochastic perturbations, the procedure of synthesis the optimal adaptive control system with explicit reference model based on gradient descent method is used, which is described in detail in [14,15].

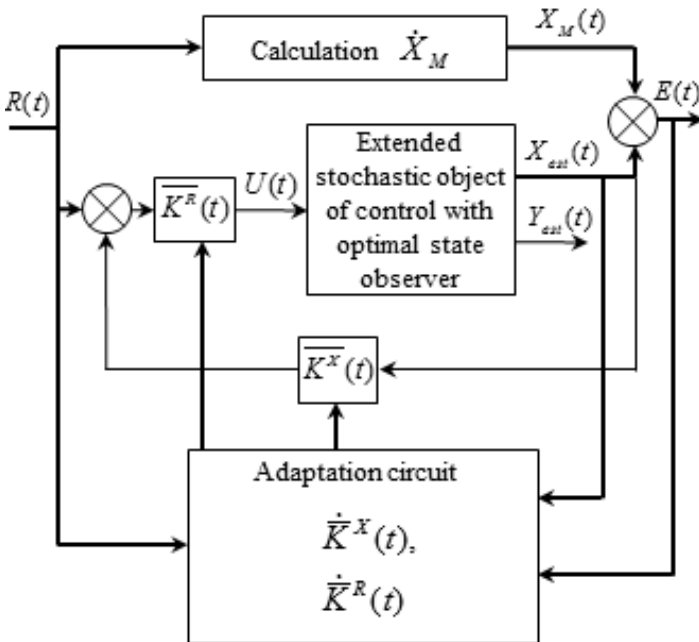

Fig.4. Block diagram of optimal adaptive control system

The results of functioning of the combined nonlinear discrete adaptive automatic control system of UAV,

which is influenced by external stochastic disturbances, are presented in Fig. 5, Fig. 6. Fig. 7, Fig. 8 present graphs of relative instant fuel economy and energy consumption managers to operate the control surfaces for speed control mode with stabilization of height.

These dependences reflect the relative decrease of energy consumption for control and fuel costs at the application of reference model, which is built based on optimal quadratic regulator with respect to the control law, which is built on the method of standard ratios. Overall average reduction of fuel costs is 15,47% and the overall average reduction in energy consumption for controlling of control surfaces is 13,24%.

In the longitudinal channel for the mode of pitch angle control maximum deviation of altitude rudders is 25 degrees. The transient process of pitch angle has aperiodic nature without static error, the time of transient process is 4 sec. At the maximum pitch angle $\Theta_{zad} = 15^\circ$ deviation in velocity is 0.2 m/sec. For speed control mode transitional processes of u also have aperiodic nature and stabilization error of height is 1%.

In the lateral channel for mode of coordinated turn overshoot of course angle is 10%. When you change the course to 1° , the maximum deviation of heel angle is also 1° . Overshoot of the angle of slip is 15%. The obtained results of reference models performance for longitudinal and lateral channel meet the requirements to the terms of UAV flight.

Thus, the results analysis of the research of the efficiency of the proposed methods in this paper showed, that using the proposed approaches can reduce network throughput (on average 15–20%), lower fuel costs (on average 13–15%), increase the efficiency of planning and re-planning of the network appreciably, reduce the cost of creating a telecommunication network in the disaster zone average of 10% in contrast with the best previously known methods. In this case, if the cost of deployment of telecommunications network is 100 million, a saving will be 10 million of USD.

Implementation and further work

The results of the work were used in the activities of the State Enterprise “Central Scientific Research Institute of Navigation and Control” and the State Research Institute of Aviation, as evidenced by relevant implementation acts. Also, the results are implemented in the educational process of the Institute of Telecommunication Systems NTUU “KPI”, National Aviation University, Institute of the government in sphere of civilian defense, and implemented in the number of research projects, that are aimed for creating a telecommunication network in the area of emergency situation.

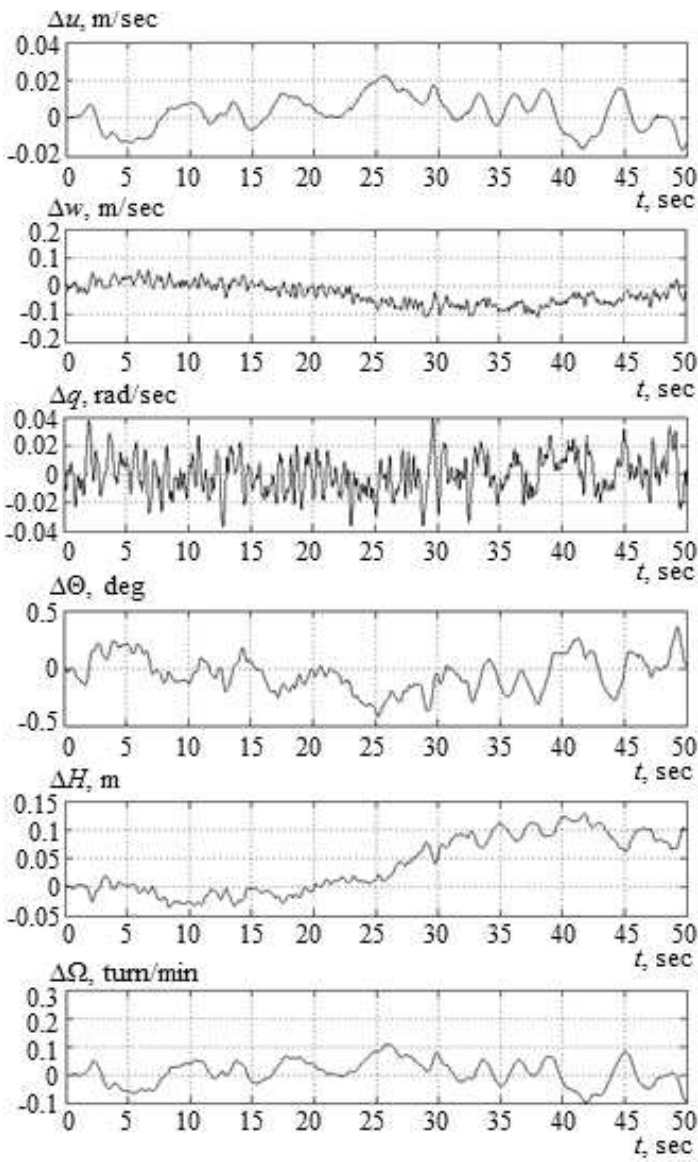

Fig.5. Error of combined nonlinear discrete adaptive automatic control system in longitudinal channel $E_i = \Delta X_i = X_i - X_{in}$

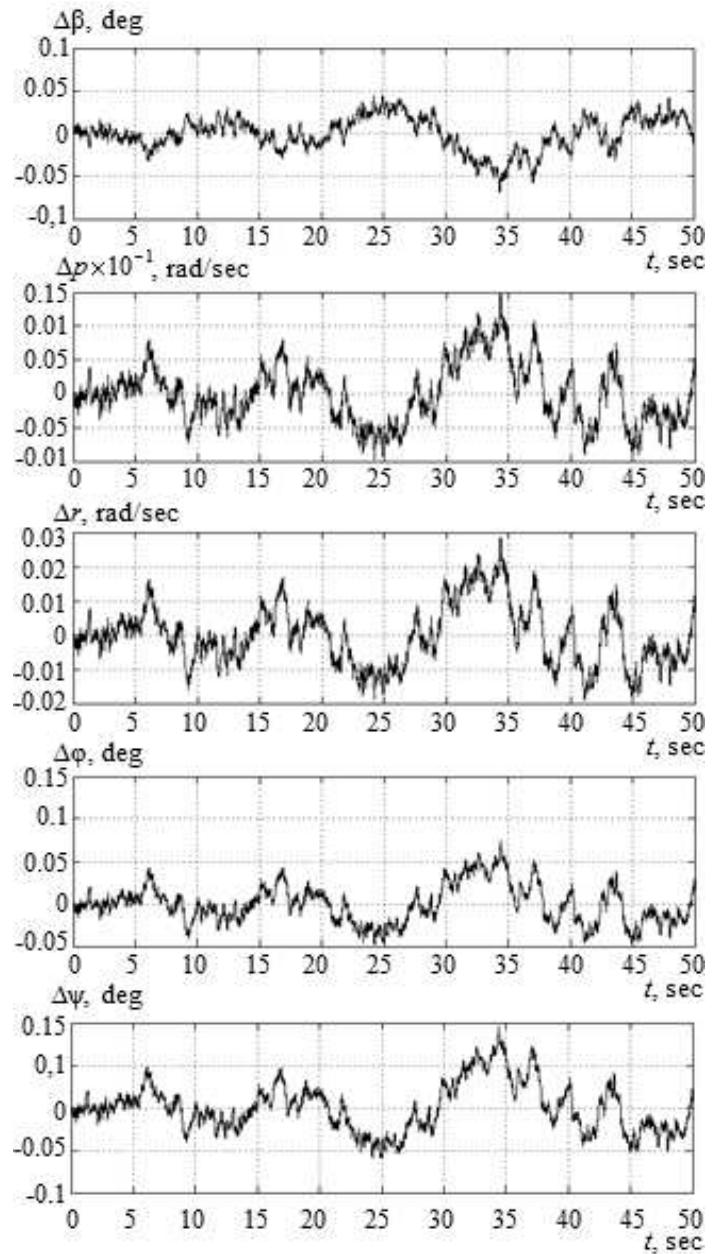

Fig.6. Error of combined nonlinear discrete adaptive automatic control system in lateral channel $E_i = \Delta Y_i = Y_i - Y_{in}$

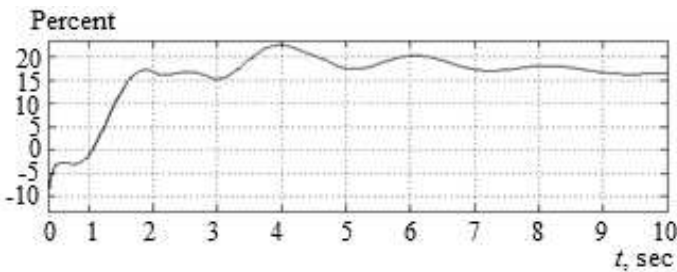

Fig.7. Change of instantaneous relative decrease of fuel costs

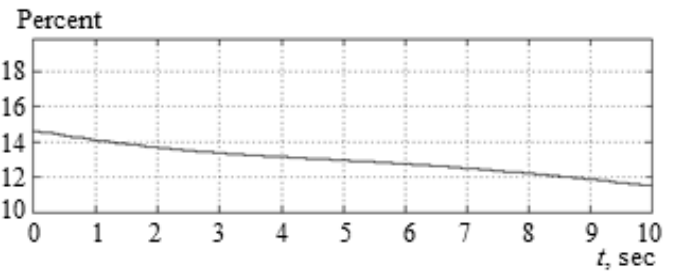

Fig.8. Change of instantaneous relative reduction of energy consumption for controlling of control surfaces

As part of further research will be the development of this method in the following areas:

1. Development of new routing methods, that will allow effectively manage the data flow for a given method of UAV network topology control.

2. Improvement of the system of input data collection, that will allow the accurate information about the current position of MS to be collected in time, monitor structural and functional changes in the network. It is possible, for example, through the deployment of wireless sensor network of ZigBee/IEEE 802.15.4 standard.

3. Improving the knowledge base of UAV placement rules that will minimize the time, spent for searching of more optimal solutions.

4. Improved methods and models for assessing the structural and functional connectivity of MS that will allow adequate prediction of the actual performance parameters of network operation.

Conclusions

This paper is devoted to analysis of method for increasing of mobile ad-hoc networks throughput, based on the placement control of unmanned aerial vehicles in view of the rapid and unpredictable movement of mobile subscribers. It is proposed a further development of this method, namely the improvement of UAV flight control subsystem that will allow operative implementation of obtained in the previous stage location coordinates while minimizing energy consumption for control. The proposed approaches will allow to improve network throughput by 15–20%, while reducing fuel costs by an average of 13–15%, increase the efficiency of planning and re-planning of the network appreciably, reduce the cost of creating a telecommunication network in the disaster zone average of 10% in contrast with the best previously known methods.

References

1. Bunin S.G., Voiter A.P., Ilchenko M.Y., Romaniuk V.A. Self-organizing radio network with ultra-wide-band signals. – K.: Naukova dumka, 2012. – 444 p.
2. Basu P. Coordinated Flocking of UAVs for Improved Connectivity of Mobile Ground Nodes / P. Basu, J. Redi, V. Shurbanov // IEEE MILCOM'04: Military Communications Conference, October 31 – November 3 2004: proceedings. – Monterey, 2004. – Vol. 3. – P. 1628–1634.
3. Chandrashekar J.S. Providing full connectivity in large ad-hoc networks by dynamic placement of aerial platforms / J.S. Chandrashekar, K. Dekhordi, M.R. Baras // In Proceedings of IEEE MILCOM'04. – 2004. – V.3. – P. 1429–1436.
4. Han Z. Smart deployment / movement of unmanned air vehicle to improve connectivity in MANET / Z. Han, A.L. Swindlehurst, K.J.R Liu // in Proc. IEEE Wireless Commun. network conference. – 2006. – V.1. – P. 252–257.
5. Minochkin A. Control System of Mobile Ad-hoc Networks / A. Minochkin, V. Romanyuk // Telecommunications and Computer Science (TCSET '08): International Conference, 19-23 Feb. 2008: proceedings. – Lviv, 2008. – P. 414–415.
6. Lysenko O. The optimal control of UAV network topology / O. Lysenko, S. Valuiskyi, O. Panchenko // **Aviation in the XXI-st century** – Safety in Aviation and Space Technologies: fourth world congress, 21-23 September 2010: proceedings. – Kyiv, 2010. – P. 1637–1640.
7. Lysenko O.I. A method of controlling the topology of aerial repeaters network to improve structural information connectivity of wireless ad hoc networks / O.I. Lysenko, I.V. Uryadnikova, S.V. Valuiskyi, I.O. Nechyporenko // Military & Science. – 2012. – vol. 7. – № 1. – P. 62 – 70.
8. Lysenko O.I., Valuiskyi S.V. Capacity increasing of sensor telecommunication networks / O.I. Lysenko, S.V. Valuiskyi // Telecommunication Sciences. – 2012. – vol. 3. – № 1. – P. 5–11.
9. Valuiskyi S. V. Evaluation of the duration of mobile subscribers connectivity of wireless ad hoc networks / S. V. Valuiskyi // Scientific Papers of Military institute of telecommunication and informatization of NTUU «KPI». – 2011. – № 3. – P. 6–11.
10. Romaniuk A. V. Methodology of estimation of performance parameters of wireless ad hoc networks with telecommunication aeroplatforms / A. V. Romaniuk // Scientific Papers of Military institute of telecommunication and informatization of NTUU “KPI”. – 2013. – № 1. – P. 59–67.
11. Tunik A.A. Robust Optimization of Control Law of Flight in Stochastically Disturbed Atmosphere / A.A. Tunik, I.K. Ahn, C.H. Yeom // Proceedings of Millennium Conference on Air and Space Sciences, Technology and Industries. – Hankook Aviation University. – Apr. 28, 2000. – Seoul, Korea. – P. 122 – 133.
12. Scogestad S. Multivariable Feedback Control / Scogestad S., Poslethwaite I. – John Wiley&Sons, 1997. – 559 p.
13. Lysenko O. Method of constructing a system of automatic control of unmanned relay aeroplatform used to enhance the connectivity of wireless ad hoc networks / O. Lysenko, P. Kirchu // Scientific Bulletin of the Academy of Municipal Management. Series “Technology”. – 2011. – № 4. – P. 101–111.
14. Lysenko O.I. Synthesis of the optimal observer of the state for the UAV adaptive control system / O.I. Lyseko, P. I. Kirchu // **Aviation in the XXI-st century** – Safety in Aviation and Space Technologies: fourth world congress, 21-23 September 2010: proceedings. – Kyiv, 2010. – P. 1645–1648.
15. Lysenko O.I. Computer certification of the robust control algorithm / O.I. Lyseko, P.I. Kirchu // **Aviation in the XXI-st century** – Safety in Aviation and Space Technologies: 3rd world congress, 22-24 September 2008: proceedings. – Kyiv, 2008. – Vol. 2. – P. 1523–1526.